

The history of the Sextant

Before the introduction of satellite-supported systems (GPS) the most important method of navigation on the high seas was the measurement of distances between constellations and the altitude of such above the horizon to the highest possible degree of exactitude. Around the ninth century the equipment used for these calculations comprised the quadrant and the astrolabe, and that was still long before the broad use of the magnetic compass. With the invention in the fourteenth century of the cross staff it was then possible to achieve even more exact readings and this piece of equipment was to remain the seaman's most important navigational instrument for the next four hundred years.

In 1731 in London, John Hadley introduced his mirror sextant. At the same time, in Philadelphia, and independently of him, Thomas Godfrey had produced the same invention. This instrument revolutionised navigation because it was now possible to take readings of, for example, the height of the sun with unsurpassed accuracy and speed. In connection with John Harrison's invention, the chronometer, the art of navigation reached heights of development never known before and one can say confidently, without exaggeration, that these two inventions were the most important prerequisites for the spreading, world wide, of the British Empire.

The principle is ingenious and at the same time amazingly simple: A rotating mirror makes it possible to bring the images of the point to be measured and of the horizon or another point of reference to coincide, and the angle of the distance between the two is simply read on a scale (more exactly: the angle produced by the lines of vision to the two points).

It is hardly surprising that the sextant was often the most precious possession of a seaman and that it is, even today, along with the anchor and the compass the most famous nautical symbol.

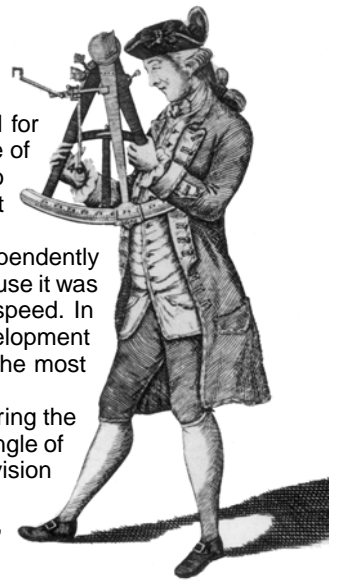

Instructions

Please read each section through beforehand! The construction is not difficult because all parts are made to fit exactly together. Each piece has its own number (A1, A2, B1, B2 etc.) and name. The letter remains the same within a group of pieces. You will need a sharp knife in order to separate the stencilled pieces from the cardboard template, a little surgical spirit to clean the mirror, a fine, waterproof felt-tip pen and naturally a serviceable adhesive. An adhesive containing solvent is recommended as opposed to the many solvent-free water-based adhesives.

Main Piece

Step 1: Remove parts A1 and A2 (main piece, front and main piece, back) from the cardboard template. Place the parts B1 and B2 (sun filter: filter holder (front) and filter slide) and C1 and C2 (index arm: front axis disc and back axis disc) aside and write the part numbers on the back. Then remove the die-cut slits from both halves of the main piece.

Step 2: Place the main piece (front) and the main piece (back), parts A1 & A2, back to back, then with a pen, mark the contours of the slits on the backs of each part and paint these markings black. These places must not be glued. The white bridge at the top of the reverse side of the main piece (A2), which protrudes over the main piece

(front), should also not be glued. That can be used to stick on an artificial horizon (optional).

Step 3: Now glue the main piece together (front and back) with the unprinted sides against each other. If the adhesive comes out of the slits you can carefully wipe it away. Let the main piece dry. It may be advisable to place a heavy book on top or something similar so that it dries completely flat.

The Sun Filter

Step 4: Glue piece B1 (filter holder: front) onto the printed side of piece B2 (filter slide), so that the point and grip are exactly covered. To test this, press the filter slide into the corresponding gap on the rear side of the main piece. The glued filter holder should then fit exactly into the gap on the front side.

Step 5: Now glue piece B4 (filter holder: back) onto the other side of the filter slide so that the point and grip are again exactly covered. Here, too, you should test the fit by pressing the filter slide into the corresponding gap. Now the filter slide is supporting the filter holder (front) on one side and on the other side the filter holder (back).

Step 6: Leave the filter slide in its gap and glue piece B3 (sun filter: slide holder) onto the back side of the main piece, so that a sort of drawer for the filter slide is made, in which it can be placed as required either with the filter holder (front) or filter holder (back) on the reverse side.

Step 7: Now glue the 18 x 36mm sun filter made from stiff, black special purpose foil into the slit of the filter holder. You may have to carefully extend the slit with a sharp knife.

unprinted sides fit together exactly. When dry, see if the axis disc fits into the corresponding hole in the main piece and is easy to turn without too much resistance or play. If either of these is the case you can widen the hole or file down the disc with the edge of a knife or a nail file.

Step 9: Remove the piece C3 (the actual swing arm of the index arm) from the cardboard template and remove the stencilled slit from the round head and the square section from the reading window. Then lay the main piece on a flat surface with the rear side (where the crossed slits are) underneath, and press the axis disc into the hole. Now glue the round head of the index arm into the middle of the axis disc. Be careful that the round head of the index arm covers the round head on the main piece and that no adhesive runs between the axis disc and the main piece. Let the glue dry well and make sure afterwards that the index arm can turn on its axis.

Step 10: Remove pieces C5 and C6 (index arm (small reinforcement piece) and index arm (minutes scale) from the cardboard template. Leave the index arm attached by the axis in the main piece and glue the small reinforcement piece flush on the back of its end where it overlaps the main piece. The minutes scale should not yet be glued, but placed temporarily between the reinforcement and the edge of the scale on the main piece in order to make sure that it can later be glued into this space.

Step 11: Make sure one more time that the index arm can freely turn on its axis. Then glue piece C4 (axis cover) onto the other, still open end of the axis. Take care that no adhesive spills over into the hole of the axis. Now the index arm is firmly bonded with the main piece.

The Viewing Chamber (Eyepiece)

Step 12: Remove the four pieces D1 (viewing chamber: rear window) from the cardboard template and remove the panes from the holes. Firstly, glue the two unprinted sides together without overlap and then again onto each side a printed piece, with the black colour to the outside. Take extra care that the flaps and the spaces are exactly on top of each other. Then remove the four pieces D2 (viewing chamber: front window) from the cardboard template and perform exactly the same procedure with them.

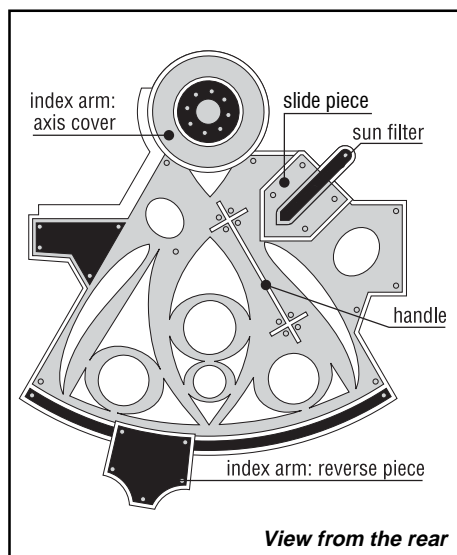

Important advice: Each time you look at the sun without a protective device you endanger your eyesight long-term. Proof of this are the poorly made sextants of earlier times, which led to many sea captains over the years going blind in one eye, their "observing eye". The sun filter in this sextant has a high content of silver and therefore offers a reliable degree of safety. Nevertheless it is a good general rule not to observe the sun longer than absolutely necessary, even through this sun filter.

The Alhidade (The Index Arm)

Step 8: Glue pieces C1 and C2 (index arm axis discs: front and back) so that the

Glue the front window (small hole) with the broad flap into the corresponding slit on the front side of the main piece (above right, in the large black area), the narrower flap pointing upwards. Then glue the rear window (large hole) with the two flaps into the corresponding slits onto the main piece (front). Here, too, the narrow flap points upwards.

Step 13: Now glue piece D3 (viewing chamber: top (outer)) and piece D4 (viewing chamber: top (inner)) together with the unprinted sides against each other. When this is dry you should then glue it onto the upper borders of both windows, so that the flaps fit into the two slots. The edge of the "roof" lengthways should lie on top of the angle made by the white protrusion of the rear side of the main piece and the front side of the main piece and is glued in that position.

Step 14: Glue piece D5 (viewing chamber: side) onto the side edges of the two windows and the "roof". Now you will see the formation of the oblong viewing chamber.

Step 15: Paint the rear side of piece D6 (viewing chamber: base) with the black felt-tip pen and write your name in the space on the front side if you wish. Now glue the piece between the side cover and the main piece flush with the bottom edges of both box windows, so that the black coloured area faces inside and the narrow gap on the long edge points to the main piece. The index arm can then swing freely into this gap. Now the viewing chamber is closed.

The Horizon Mirror

Step 16: Remove the protective foil from the polished surfaces of both mirrors. It is possible that you may observe a residue of melted foil along the edges of the mirrors. In order to avoid any mechanical stress that could result in a warping of their surfaces, these mirrors are cut with a laser from polished stainless steel, and it is possible that the protective foil could melt in the area where the laser has cut. This residue is easy to remove with white spirit and a soft cloth. Take care whilst doing this that you don't scratch the surface of the mirrors.

Step 17: Remove the four parts of piece E1 (support: horizon mirror) from the cardboard template and glue the two unprinted ones against each other and then on each side a printed one. Take good care that the edges are flush and no side overlaps another. Place the mirror in the long slit that is found on the left of the main piece (front) with the polished side facing the viewing chamber. Place the support (E1) with its short edge in the slit that runs at a right angle to the mirror and shove the support from behind against the mirror until it presses firmly against the edge of the slit. Glue mirror and support in this position in their slit and firmly onto each other. Important: Take care that the mirror stands at a right angle on the main piece. You can test that with one of the right-angled corner pieces of the cardboard or by viewing in the mirror whilst holding the surface level with the eyes. The surface of the main piece will continue in the mirror without a kink.

Step 18: Glue piece E2 (horizon mirror: upper cover) in the upper corner angle between the horizon mirror and its support, so that the slit behind the mirror is covered. In the corner angle on the other side of the

support glue the piece E3 (horizon mirror: lower cover).

The Index Mirror

Step 19: Glue the four parts of piece F1 (support: index mirror) in the same way as described in step 17 for the support of the horizon mirror. Glue the second mirror with its support into the head of the index arm in exactly the same way as with the first mirror. Here too the support is glued onto the non-polished side of the mirror. Take care that the adhesive touches only the axis disc, otherwise the index arm will no longer be able to turn.

Step 20: The index mirror must also stand vertically and exact. This can be tested as follows: Set the index arm to a reading somewhere between 35° and 40° and take a level viewing from above the index arm head into the mirror. If the mirror is correctly placed, the reflected and non-reflected curved edges of the main piece will meld into each other without a kink. In addition the semicircular half head of the index arm becomes a perfect circle when viewed in the perfectly vertical mirror. You should carefully control this before the adhesive has completely dried, in case the positioning of the mirror needs adjustment.

The Handle

Step 21: Glue the two unprinted reinforcement pieces (G3 and G4) onto each other and then the main pieces (G1 and G2) on both sides. Do exactly the same with pieces G5 and G6 (handle: bases 1 and 2). Take good care here too that the edges are flush and that there are no overlapping parts. Test whether both the base pieces are easily inserted at a right angle in the corresponding slits of the main piece. Next glue both the base pieces at right angles into the cross-shaped slits on the rear side of the main piece and then insert and glue the main piece of the handle onto that.

Calibration of the Minutes Scale

Step 22: Quite near the horizon mirror on the main piece you will find imprinted a small arrow. Using a black, fine felt-tip pen draw a small, clearly visible line on the upper, free-standing longitudinal border of the horizon mirror at exactly the same level the arrow is. This is how you test whether the line is in exactly the right place: Swing the index arm beyond the 100° mark until it touches the horizon mirror. If you now take a view through the viewing chamber window you see, in the upper area, the index mirror, which appears as a narrow, squashed-together rectangle. The marking line you have drawn on the horizon mirror must lie exactly in the middle of this narrow rectangle. It may be necessary to remove the marking line with white spirit and draw it again.

Step 23: Turn the index arm until the horizon mirror and the index mirror are about parallel and you can read 5° in the middle of the reading window.

Then, through both the observation windows, get a fix on a distant horizontal line, for example the horizon itself or the flat roof of a large building. The distance should be at least a mile away. At the left side of your field of vision the non-reflected view goes straight on past the horizon mirror. At the right side it falls upon the horizon mirror, which steers your view to the index mirror

from where it goes straight on again. Now carefully turn the index arm slightly back and forth, until the observed horizontal line runs, without a break, from the the non-reflected picture into the reflected picture, that is, exactly where you have drawn the marking line on the horizon mirror. If both the mirrors are correctly lined up, the reflected picture and the non-reflected picture appear as a single seamless unit. You should now provisionally fix the index arm in this position with, for instance, a clothes peg.

Step 24: Now glue piece C6 (index arm: minutes scale) behind the foot of the index arm between the small reinforcement piece and the main piece. In doing this, the little arrow at the 0 minutes mark must point exactly on the 0° mark of the scale on the main piece. Then test whether a unified, constant, unbroken image appears in the viewing chamber when the arrow of the minutes scale lies on 0°. If necessary, correct the minutes scale again before the glue is dry.

Step 25: Now glue piece C7 (index arm: large reinforcement piece) on the back of the minutes scale and the small reinforcement piece and then glue piece C8 (index arm: reverse piece), on which the directions for reading the sextant are found, onto piece C7. The reverse piece grips from under the rear side of the main piece and gives the index arm a firm hold. Take good care that it can always swing freely. If you wish to improve the calibration after the minutes scale is already glued in place, you can always shift the black marking line on the horizon mirror to help you. It is possible to remove it with white spirit and to replace it until you have a satisfactory result.

Now your sextant is complete.

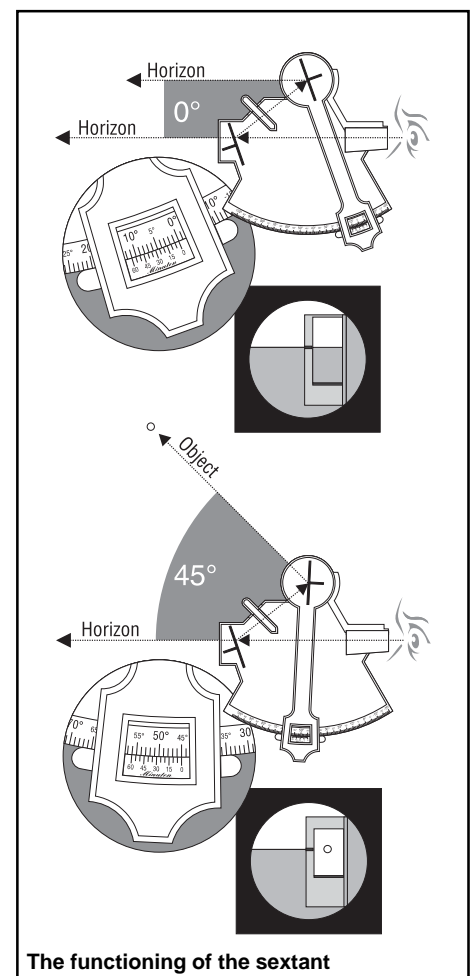

The functioning of the sextant

Taking readings with the Sextant

With your completed sextant you are in command of a very versatile instrument. You can determine positions and courses, measure angles, distances and heights. The following gives you several examples. There are many books and instructional literature regarding the practical use of sextants.

Calculating latitude using the height of the sun

1. Insert the sun filter so that it is positioned between the mirrors.
2. Place the index arm on 0°.
3. Direct the sextant towards the sun so that its reflection appears through the filter.

Caution: Only take a bearing on the sun through the filter, never directly! It is safest is to hold the sextant not by its handle but by the protruding cardboard edge behind the horizon mirror. In this way the hand blocks the direct look at the sun.

4. Slowly lower the sextant and simultaneously swing the index arm forwards. The reflected image of the sun should always remain visible.

5. Take the reading when the reflected image of the sun stands exactly next to the line of the horizon and both are level with the black marking line. From the height of the sun above the horizon, i.e. its altitude, measured at true noon (that is, when the sun is exactly in the south and consequently at its highest point), the **geographical latitude of your position** can be determined. To do this it is necessary to know the declination of the sun at a given date (i.e. its distance from the celestial equator. See the table alongside). The latitude is then calculated in two simple steps.

I. **Altitude of celestial equator = measured altitude of the sun minus declination of the sun.**

II. **Latitude = 90° minus altitude of celestial equator.**

Example: It is the 1 August and you want to know the latitude of your location. At midday, when the sun stands exactly in the south, you measure the altitude of the sun. It comes to 59°30'. In the "year chart" you look up the sun-declination for 1 August, which is 17°51'. You calculate:

I. **Altitude of celestial equator = 59°30' - 17°51' = 41°39'**

II. **Latitude of your location = 90° - 41°39' = 48°21'**

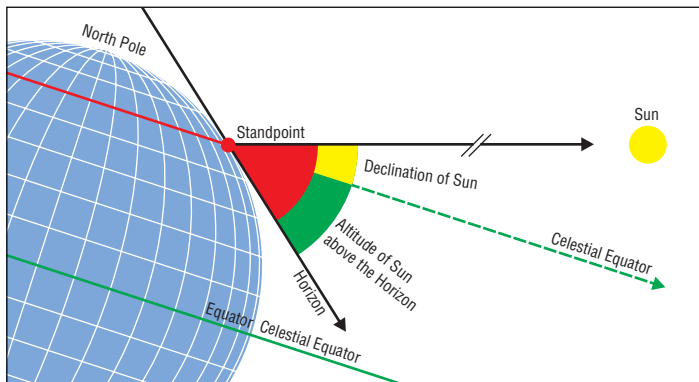

Calculation of angular extension between two points

In order to determine the angular extension between two points on land, e.g. the summits of mountains near the coast, hold the sextant horizontally and swing the index arm so that you bring the non-reflected image of one point in line with the reflected image of the other point. By taking several readings of the angular extension to various landmarks it is possible, with the help of a map and a protractor, to calculate the distance.

In a similar fashion you can, if you know the distance, diagrammatically calculate the height of a landmark or building. You first measure the angle between the horizontal and the top of the building (a) and then the angle between the horizontal and the ground border (b), and put the results on paper in the form of a diagram. For this type of calculation the scale of the sextant goes to -5° under the 0 mark. You must however realize that results taken from measuring smaller distances and larger angles will be less exact. The reason: The reflected line of vision intersects with the non-reflected line of vision at different points depending on the position of the index arm, because it reaches the eye not directly, but through the two mirrors. This resulting displacement is called a *parallax*. However, when one is working with smaller angles and very distant objects, like the stars, the differences are minimal to non-existent.

Year chart of sun declination

01.01. -23°02'	15.03. -1°54'	28.05. 21°34'	10.08. 15°23'	23.10. -11°37'
02.01. -22°57'	16.03. -1°30'	29.05. 21°43'	11.08. 15°05'	24.10. -11°58'
03.01. -22°52'	17.03. -1°06'	30.05. 21°52'	12.08. 14°47'	25.10. -12°19'
04.01. -22°46'	18.03. 0°42'	31.05. 22°00'	13.08. 14°29'	26.10. -12°39'
05.01. -22°39'	19.03. 0°19'	01.06. 22°08'	14.08. 14°10'	27.10. -13°00'
06.01. -22°33'	20.03. 0°05'	02.06. 22°16'	15.08. 13°51'	28.10. -13°20'
07.01. -22°25'	21.03. 0°29'	03.06. 22°23'	16.08. 13°32'	29.10. -13°40'
08.01. -22°18'	22.03. 0°52'	04.06. 22°30'	17.08. 13°13'	30.10. -13°59'
09.01. -22°09'	23.03. 1°16'	05.06. 22°37'	18.08. 12°54'	31.10. -14°19'
10.01. -22°01'	24.03. 1°40'	06.06. 22°43'	19.08. 12°34'	01.11. -14°38'
11.01. -21°52'	25.03. 2°03'	07.06. 22°49'	20.08. 12°14'	02.11. -14°57'
12.01. -21°42'	26.03. 2°27'	08.06. 22°54'	21.08. 11°54'	03.11. -15°15'
13.01. -21°33'	27.03. 2°50'	09.06. 22°59'	22.08. 11°34'	04.11. -15°34'
14.01. -21°22'	28.03. 3°14'	10.06. 23°03'	23.08. 11°14'	05.11. -15°52'
15.01. -21°12'	29.03. 3°37'	11.06. 23°08'	24.08. 10°53'	06.11. -16°10'
16.01. -21°01'	30.03. 4°00'	12.06. 23°11'	25.08. 10°32'	07.11. -16°28'
17.01. -20°49'	31.03. 4°24'	13.06. 23°15'	26.08. 10°12'	08.11. -16°45'
18.01. -20°37'	01.04. 4°47'	14.06. 23°18'	27.08. 9°51'	09.11. -17°02'
19.01. -20°25'	02.04. 5°10'	15.06. 23°20'	28.08. 9°29'	10.11. -17°19'
20.01. -20°12'	03.04. 5°33'	16.06. 23°22'	29.08. 9°08'	11.11. -17°36'
21.01. -19°59'	04.04. 5°56'	17.06. 23°24'	30.08. 8°47'	12.11. -17°52'
22.01. -19°46'	05.04. 6°18'	18.06. 23°25'	31.08. 8°25'	13.11. -18°08'
23.01. -19°32'	06.04. 6°41'	19.06. 23°26'	01.09. 8°03'	14.11. -18°23'
24.01. -19°18'	07.04. 7°04'	20.06. 23°26'	02.09. 7°41'	15.11. -18°39'
25.01. -19°03'	08.04. 7°26'	21.06. 23°26'	03.09. 7°19'	16.11. -18°54'
26.01. -18°49'	09.04. 7°48'	22.06. 23°26'	04.09. 6°57'	17.11. -19°08'
27.01. -18°33'	10.04. 8°11'	23.06. 23°25'	05.09. 6°35'	18.11. -19°22'
28.01. -18°18'	11.04. 8°33'	24.06. 23°24'	06.09. 6°12'	19.11. -19°36'
29.01. -18°02'	12.04. 8°54'	25.06. 23°22'	07.09. 5°50'	20.11. -19°50'
30.01. -17°46'	13.04. 9°16'	26.06. 23°20'	08.09. 5°27'	21.11. -20°03'
31.01. -17°29'	14.04. 9°38'	27.06. 23°18'	09.09. 5°05'	22.11. -20°16'
01.02. -17°12'	15.04. 9°59'	28.06. 23°15'	10.09. 4°42'	23.11. -20°28'
02.02. -16°55'	16.04. 10°20'	29.06. 23°12'	11.09. 4°19'	24.11. -20°40'
03.02. -16°38'	17.04. 10°42'	30.06. 23°08'	12.09. 3°56'	25.11. -20°52'
04.02. -16°20'	18.04. 11°03'	01.07. 23°04'	13.09. 3°33'	26.11. -21°03'
05.02. -16°02'	19.04. 11°23'	02.07. 22°59'	14.09. 3°10'	27.11. -21°14'
06.02. -15°44'	20.04. 11°44'	03.07. 22°54'	15.09. 2°47'	28.11. -21°25'
07.02. -15°26'	21.04. 12°04'	04.07. 22°49'	16.09. 2°24'	29.11. -21°35'
08.02. -15°07'	22.04. 12°24'	05.07. 22°44'	17.09. 2°01'	30.11. -21°45'
09.02. -14°48'	23.04. 12°44'	06.07. 22°37'	18.09. 1°38'	01.12. -21°54'
10.02. -14°28'	24.04. 13°04'	07.07. 22°31'	19.09. 1°14'	02.12. -22°03'
11.02. -14°09'	25.04. 13°24'	08.07. 22°24'	20.09. 0°51'	03.12. -22°11'
12.02. -13°49'	26.04. 13°43'	09.07. 22°17'	21.09. 0°28'	04.12. -22°19'
13.02. -13°29'	27.04. 14°02'	10.07. 22°09'	22.09. 0°04'	05.12. -22°27'
14.02. -13°09'	28.04. 14°21'	11.07. 22°01'	23.09. 0°19'	06.12. -22°34'
15.02. -12°49'	29.04. 14°39'	12.07. 21°53'	24.09. 0°42'	07.12. -22°41'
16.02. -12°28'	30.04. 14°58'	13.07. 21°44'	25.09. -1°06'	08.12. -22°47'
17.02. -12°07'	01.05. 15°16'	14.07. 21°35'	26.09. -1°29'	09.12. -22°53'
18.02. -11°46'	02.05. 15°34'	15.07. 21°25'	27.09. -1°53'	10.12. -22°58'
19.02. -11°25'	03.05. 15°51'	16.07. 21°16'	28.09. -2°16'	11.12. -23°03'
20.02. -11°03'	04.05. 16°09'	17.07. 21°05'	29.09. -2°39'	12.12. -23°07'
21.02. -10°42'	05.05. 16°26'	18.07. 20°55'	30.09. -3°03'	13.12. -23°11'
22.02. -10°20'	06.05. 16°43'	19.07. 20°44'	01.10. -3°26'	14.12. -23°15'
23.02. -9°58'	07.05. 16°59'	20.07. 20°33'	02.10. -3°49'	15.12. -23°18'
24.02. -9°36'	08.05. 17°15'	21.07. 20°21'	03.10. -4°12'	16.12. -23°21'
25.02. -9°14'	09.05. 17°31'	22.07. 20°09'	04.10. -4°35'	17.12. -23°23'
26.02. -8°52'	10.05. 17°47'	23.07. 19°57'	05.10. -4°58'	18.12. -23°24'
27.02. -8°29'	11.05. 18°02'	24.07. 19°44'	06.10. -5°21'	19.12. -23°26'
28.02. -8°07'	12.05. 18°17'	25.07. 19°31'	07.10. -5°44'	20.12. -23°26'
29.02. -7°44'	13.05. 18°32'	26.07. 19°18'	08.10. -6°07'	21.12. -23°27'
01.03. -7°21'	14.05. 18°47'	27.07. 19°04'	09.10. -6°30'	22.12. -23°26'
02.03. -6°58'	15.05. 19°01'	28.07. 18°50'	10.10. -6°53'	23.12. -23°26'
03.03. -6°35'	16.05. 19°15'	29.07. 18°36'	11.10. -7°15'	24.12. -23°24'
04.03. -6°12'	17.05. 19°28'	30.07. 18°21'	12.10. -7°38'	25.12. -23°23'
05.03. -5°49'	18.05. 19°41'	31.07. 18°07'	13.10. -8°00'	26.12. -23°21'
06.03. -5°26'	19.05. 19°54'	01.08. 17°51'	14.10. -8°23'	27.12. -23°18'
07.03. -5°02'	20.05. 20°06'	02.08. 17°36'	15.10. -8°45'	28.12. -23°15'
08.03. -4°39'	21.05. 20°19'	03.08. 17°20'	16.10. -9°07'	29.12. -23°12'
09.03. -4°15'	22.05. 20°30'	04.08. 17°04'	17.10. -9°29'	30.12. -23°08'
10.03. -3°52'	23.05. 20°42'	05.08. 16°48'	18.10. -9°51'	31.12. -23°03'
11.03. -3°28'	24.05. 20°53'	06.08. 16°32'	19.10. -10°12'	
12.03. -3°05'	25.05. 21°04'	07.08. 16°15'	20.10. -10°34'	
13.03. -2°41'	26.05. 21°14'	08.08. 15°58'	21.10. -10°55'	
14.03. -2°17'	27.05. 21°24'	09.08. 15°40'	22.10. -11°16'	

The above values are for the year 2004, in each case at 12.00h midday. In other years the values change in the "minutes" area (negative values: The sun is **beneath** the celestial equator)

